

SCHWINN[®]

1971 SPECIFICATIONS

For ● Paramount Models

● Sports Tourer

● Super Sports

the Choice of Champions



Paramount® Tandem ten-speed model T19/T22

DESCRIPTION • PARAMOUNT TANDEM

WHEEL SIZE 27"		MODEL NO. T19-9		
FRAME SIZE 22" Front		PRICE*		
	ZONE 1	ZONE 2	ZONE 3	
19" Rear	\$475.00	\$477.00	\$478.00	
24" Front				
22" Rear				

DESCRIPTION • PARAMOUNT TANDEM

WHEEL SIZE 27"		MODEL NO. T22-9		
FRAME SIZE 22" Front		PRICE*		
	ZONE 1	ZONE 2	ZONE 3	
22" Rear	\$475.00	\$477.00	\$478.00	
24" Front				
24" Rear				

1. FRAME: The frame is manufactured from chrome-molybdenum alloy steel. The frame tube ends are further reinforced with pressed in sleeves. The use of this steel alloy combines strength with a very low total weight. All Paramount Tandem frames are hand assembled.

2. FRAME SPECIFICATIONS: The T19 model Paramount Tandem has a 22" front seat mast and a 19" rear seat mast. The shorter rear seat mast, along with a variation in the placement of the rear top tube, allows a shorter rider to easily mount and ride the T19 Paramount Tandem. The T19 Paramount is also available in a larger frame size of 24" front and 22" rear seat mast. The T22 model Paramount Tandem is available with either 22" or 24" seat mast front and rear.

3. FORK: The fork is manufactured from chrome-molybdenum alloy steel combining lightweight with strength.

4. WHEELS: Assembled with Weinmann aluminum alloy rims and Campagnolo Road high flange alloy hubs. The hubs are equipped with a quick release mechanism which allows the wheels to be easily removed without tools.

5. HANDLEBARS: Front handlebar is aluminum alloy road racing drop style handlebar. Rear handlebar is "All Rounder" aluminum alloy handlebar.

6. BRAKES: The Paramount Tandem is equipped with special Mafac tandem brakes. The brake arms pivot on special welded-on studs. Brake levers are Weinmann hooded levers with quick release mechanism built into hand lever to allow easy removal of wheels.



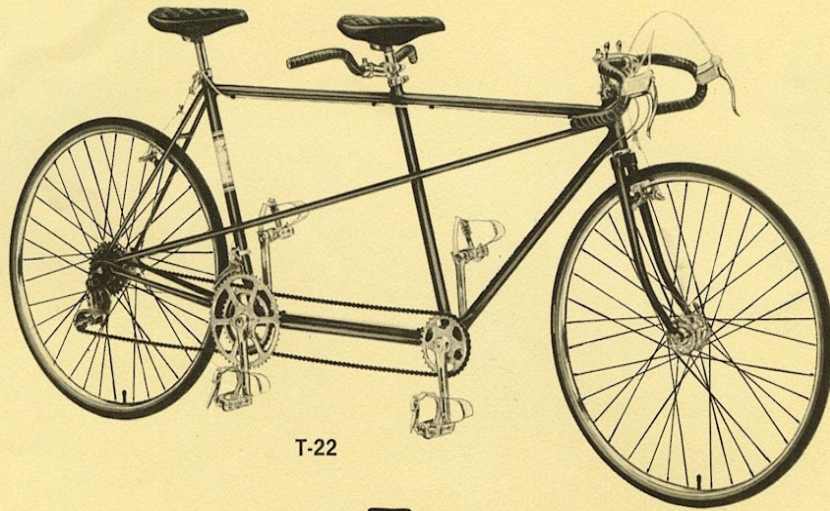

T-22

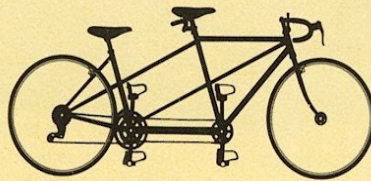

T-19

7. CRANK SETS: Front and rear cranks are aluminum alloy cranks 170MM (approx. 6 $\frac{3}{4}$ "") in length. The front crank has a sprocket of 32 teeth. The rear crank has driving sprockets of 52 and 36 teeth and a 32 tooth sprocket which is connected to the front sprocket.

8. PEDALS: Campagnolo Road racing pedals with Christophe toe clips and Alfredo Binda toe straps.

9. DERAILLEURS: Rear derailleur is Campagnolo Gran Turismo. Front derailleur is Campagnolo Record. Both derailleurs are operated from Schwinn Twin-Stik control mounted on the frame head. Rear sprockets used on Paramount Tandems are Regina "Gold" freewheel cluster with sprockets of 14, 16, 19, 25 and 31 teeth.

10. GEAR RANGE: The gear range is 31 to 100 with the steps as follows:

36-31 31	36-25 39	52-31 45	36-19 51	52-25 56
36-16 61	36-14 69	52-19 74	52-16 88	52-14 100

11. SADDLES: Both saddles are Unica-Nitor nylon saddles with waffle top.

12. SEAT POSTS: Campagnolo seat posts.

13. WEIGHT: 43 pounds. Weight may vary depending on frame size and accessories.

14. TOOLS: All Paramount Tandems are equipped with a tool kit containing a Campagnolo wrench for adjusting the seat posts and a set of T. A. Crank tools for disassembling and adjusting the cranks.

WHAT YOU CAN ORDER ON THE PARAMOUNT TANDEM

1. TIRE AND TUBE OPTIONS:

Wired on high pressure 27" x 1 $\frac{1}{4}$ " road racing tires are supplied as standard equipment.

Puncture-resistant tubes (for above road racing tires only)

..... \$5.00 per pair extra cost

Clementi Campionato del Mondo sew-up tires with butyl tubes on Mavic Professional rims may be ordered at an extra cost of

..... \$12.95 per pair extra cost

2. COLOR OPTIONS:

Radiant Colors—Campus Green, Sky Blue, Violet, Flamboyant Red, Sierra Brown, Coppertone, or Burgundy.

Opaque Colors—Kool Lemon, Kool Orange, Black, White or Silver.

*Fair trade retail price in Fair Trade States. Suggested retail price in all other states. Prices and specifications subject to change without notice. Zone 2 and Zone 3 prices reflect higher shipping costs.

SCHWINN



Professional Road Racing Paramount®
 ————— ✦ ————— ten-speed model P13
 Deluxe Paramount® fifteen-speed model P15

**DESCRIPTION • PROFESSIONAL ROAD RACING
 PARAMOUNT • MODEL NO. P13-9
 DELUXE PARAMOUNT • MODEL NO. P15-9**

WHEEL SIZE 27"	FRAME SIZE 20" to 26"	PRICE*		
		ZONE 1	ZONE 2	ZONE 3
		\$350.00	\$352.00	\$353.00

**THE EQUIPMENT ON THE PROFESSIONAL ROAD
 RACING AND DELUXE PARAMOUNT**

1. FRAME COMPONENTS: All frame components on the P13 and P15 Paramount models are manufactured from Reynolds 531 double butted tubing. The decal on the seat mast which reads "Guaranteed built with Reynolds 531 butted tubes, forks, and stays," makes these three important points:

(a). The entire frame is manufactured from Reynolds 531 butted tubing.

(b). Butted tubes are manufactured in such a way that at the points of greatest stress (near the brazed joints), the gauge of the tubing is thickened without, however, increasing the outside diameter. Double butted tubing therefore, is able to combine the ultimate in lightness with the ultimate in strength.

(c). "531" tubing is unaffected by the temperatures required in the hand brazing operation. The tubing therefore retains all of its original strength at the greatest points of stress.

Additionally, all joints are further reinforced with Nervex Professional cut lugs. The rear stays are equipped with Campagnolo rear fork ends.

All frame components are hand assembled.

2. FRAME SPECIFICATIONS: The P13 and P15 Paramounts are available in seven frame sizes ranging from 20" to 26" (frame sizes are measured from the center of the crank hanger to the top of the seat mast). The head and seat mast are parallel with each other and form a 73° angle with the wheelbase center line.

3. FRAME TRIM: Chrome trim on the head lugs, fork crown, six inches of chrome trim on the rear fork and stays and the front fork.

4. FORK: The fork is manufactured from Reynolds 531 butted tubing which again, combines the best in lightness with the best in strength and resiliency. The fork has a 2° rake and is equipped with Campagnolo Gran Sport fork tips.

5. WHEELS: Assembled with Weinmann aluminum alloy rims on Campagnolo Record large flange road hubs. The spokes are .080-.060 gauge and are chrome plated. The hubs are equipped with a quick release mechanism allowing the wheels to be removed without the use of tools.

6. TIRES: Standard equipment tires on the Professional Road Racing Paramount are Clementi No. 50 sew-up tires. The Deluxe Paramount is equipped with wired-on high pressure 27" x 1 1/4" tires.

7. HANDLEBAR: Cinelli aluminum alloy drop style handlebars with Maes style road racing bend.

8. CRANK SET: The P13 Paramount is equipped with a double plateau Campagnolo Nouvo Record crank set. This crank is a three-piece aluminum alloy crank set with 170MM (6 3/4") crank arms. The chainwheels are of aluminum alloy also and have 49 and 52 teeth.

The P15 Paramount is equipped with a triple plateau Campagnolo Nouvo Record crank set. This crank is a three-piece aluminum alloy with 170MM (6 7/8") crank arms. The chainwheels are aluminum alloy also and have 36, 49 and 54 teeth.

9. PEDALS: Campagnolo Pedals with Christophe toe clips and Alfredo Binda toe straps.

10. SADDLE: Brooks Professional all-leather saddle. All leather saddles used on Paramount models are "broken-in" at the Schwinn factory.

11. DERAILLEURS AND FREEWHEEL: P13 Professional Road Racing Paramount—Campagnolo Nouvo Record rear derailleur and Campagnolo Record front derailleur. The derailleurs are operated from shifting levers located on the bottom bar. The freewheel is Regina and has sprockets of 14, 16, 18, 23 and 26 teeth.

P15 Deluxe Paramount—Campagnolo Gran Turismo derailleur and Campagnolo Record front derailleur. The derailleurs are operated from shifting levers located on the bottom bar. The freewheel has sprockets of 14, 16, 19, 25 and 31 teeth.

12. GEAR RANGE: The gear range on the P13 Professional Road Racing Paramount is **51 to 100** with the steps as follows:
 49-26 **51** 52-26 **54** 49-23 **58** 52-23 **61** 49-18 **74**
 52-18 **78** 49-16 **83** 52-16 **88** 49-14 **95** 52-14 **100**
 The gear range on the P15 Deluxe Paramount is **31 to 104** with the steps as follows:

36-31 **31** 36-25 **39** 49-31 **43** 54-31 **47** 36-19 **51**
 49-25 **53** 54-25 **58** 36-16 **61** 36-14 **69** 49-19 **70**
 54-19 **77** 49-16 **83** 54-16 **91** 49-14 **95** 54-14 **104**

13. TOOLS: Included with both the Paramount models is a tool kit containing Campagnolo tools for disassembling and adjusting the crank set, for adjusting the saddle and seat post and for adjusting the derailleurs.

14. COLORS: Paramount models are available in your choice of all Schwinn colors or all chrome finish.

15. WEIGHT: P13—23 lbs., P15—25 lbs. (Weight will vary depending on frame size, options and accessories).

16. USE AND PURPOSE: The P13 Road Racing Paramount, as the name implies, is intended primarily for competitive road racing or fast touring in cycling clubs. The standard equipment items such as sew-up tires, relatively narrow gear range, and shorter wheelbase frame are intended to make the P13 Paramount the best in professional road racing equipment. The competitive purpose of the P13 also dictates the choice of the available options such as choice of sprocket sizes, controls, and brakes.

The P15 Deluxe Paramount, on the other hand, is primarily intended for general touring. The very broad gear range makes the P15 especially suited for touring in hilly or mountainous terrain. In addition, the frame stays and bridges are designed to accommodate touring equipment such as clincher (wired-on) tires and fenders. The frame construction and the use of broad range derailleurs also make the use of Campagnolo fingertip controls and Campagnolo brakes impractical on the P15 Deluxe Paramount.

OPTIONS AVAILABLE ON P13 AND P15 PARAMOUNT MODELS

1. FRAME OPTIONS:

Standard size frames of 20", 21", 22", 23", 24", 25" or 26" may be ordered at.....*no extra cost*
 Custom built, made to measure frame..... *\$40.00 extra cost*
 (For complete information on frame sizes, see page 6.)

2. SADDLE OPTIONS:

Brooks Professional all-leather saddle.....*standard equipment*
 Unica-Nitor nylon saddle.....*no extra cost*

3. COLOR OPTIONS:

Radiant Colors—Campus Green, Sky Blue, Violet, Red, Sierra Brown, Coppertone, Burgundy.
 Opaque Colors—Kool Lemon, Kool Orange, Black, White, Silver Mist.
 All chrome finish.....*no extra cost*

OPTIONS AVAILABLE ON THE P13 PROFESSIONAL ROAD RACING PARAMOUNT ONLY

1. TIRE AND TUBE OPTIONS:

Clementi No. 50 sew-up tires on Weinmann aluminum alloy hollow rims.....*standard equipment*
 Clementi Campionato del Mondo sew-up tires with butyl tubes on Weinmann aluminum alloy wood filled rims.....*\$12.95 per pair extra cost*

2. SPROCKET SIZE OPTIONS:

49-52T front sprockets.....*standard equipment*
 42-52T front sprockets.....*no extra cost*
 45-52T front sprockets..... *\$2.50 extra cost*
 14, 16, 18, 23 and 26T rear sprockets.....*standard equipment*
 14, 16, 18, 21 and 24T rear sprockets.....*no extra cost*

3. CONTROL OPTIONS:

Bottom bar mounted controls.....*standard equipment*
 Schwinn Twin-Stik Controls.....*no extra cost*
 Campagnolo fingertip handlebar mounted controls.....*\$10.95 extra cost*

4. BRAKE OPTIONS:

Schwinn Approved (Weinmann) center pull caliper brakes.....*standard equipment*
 Campagnolo side pull caliper brakes..... *\$50.00 extra cost*

5. OTHER OPTIONS:

Dual Position Caliper Levers.....*no extra cost*
 Heavy Duty Spokes .092-.080g..... *\$4.00 extra cost*

OPTIONS AVAILABLE ON THE P15 DELUXE PARAMOUNT ONLY

1. TIRE AND TUBE OPTIONS:

Wired-on road racing high pressure 27" x 1 1/4" tires.....*standard equipment*
 Puncture resistant tubes (for above tires only) . . . *\$5.00 extra cost*
 Clementi No. 50 sew-up tires on Weinmann aluminum alloy hollow rims..... *\$6.95 per pair extra cost*
 Clementi Campionato del Mundo sew-up tires with butyl tubes on Weinmann aluminum alloy wood filled rims.....*\$12.95 per pair extra cost*

2. CONTROL OPTIONS:

Bottom bar mounted controls.....*standard equipment*
 Schwinn Twin-Stik Controls.....*no extra cost*

3. OTHER OPTIONS:

Chrome plated steel fenders..... *\$7.95 extra cost*
 Heavy duty spokes .092-.080g..... *\$4.00 extra cost*

*Fair trade retail price in fair trade states. Suggested retail price in all other states. Prices and specifications subject to change without notice. Zone 2 and Zone 3 prices reflect higher shipping costs.

SCHWINN

Paramount® Track Bike fixed hub model P14

DESCRIPTION • PARAMOUNT TRACK BIKE

	MODEL NO. P14-0		
	PRICE*		
WHEEL SIZE 27"	ZONE 1	ZONE 2	ZONE 3
FRAME SIZE 20" to 26"	\$224.95	\$226.95	\$227.95

THE EQUIPMENT ON THE PARAMOUNT TRACK BIKE

1. FRAME COMPONENTS: All frame components on the Paramount Track Bike are manufactured from Reynolds 531 double butted tubing. The decal on the seat mast which reads "Guaranteed built with Reynolds 531 butted tubes, forks and stays," makes these three important points:

(a). The entire frame is manufactured from Reynolds 531 butted tubing.

(b). Butted tubes are manufactured in such a way that, at the points of greatest stress near the brazed joints, the gauge of the tubing at the ends is thickened without increasing the outside diameter. Double butted tubing therefore, is able to combine the ultimate in lightness with the ultimate in strength.

(c). "531" tubing is unaffected by the temperatures required in the hand brazing operation. The tubing therefore retains all of its original strength at the greatest points of stress. Additionally, all joints are further reinforced with Professional cut lugs. The rear stays are equipped with Campagnolo Record Track rear fork ends.

All frame components are hand assembled.

2. FRAME SPECIFICATIONS: The Paramount Track Bike is available in seven frame sizes ranging from 20" to 26". The head and seat mast are parallel with each other and form a 74° angle with the wheelbase center line.

3. FRAME TRIM: Paramount Track Bikes have six inches of chrome trim on the rear fork and stays and the front fork.

4. FORK: The fork is manufactured from Reynolds 531 butted tubing which again, combines the best in lightness with the best in strength and resiliency. The fork has a 1 1/8" rake and is equipped with Campagnolo Record Track fork tips and chrome-molybdenum crown.

5. WHEELS: Assembled with Weinmann aluminum alloy wood filled rims on Campagnolo Track large flange hubs. The spokes are .080-.060 gauge and are chrome plated.

6. TIRES: Paramount Track Bikes are equipped with Clementi No. 3 silk sew-up track tires.

7. HANDLEBAR: Cinelli steel track drop style handlebar with Cinelli steel track stem.

8. CRANK SET: The Paramount Track Bike may be ordered with either 165MM (6 1/2") or 170MM (6 3/4") Campagnolo Pista track crank sets.

9. PEDALS: Campagnolo Track pedals with Christophe toe clips and Alfredo Binda toe straps.

10. SADDLE: Brooks Professional all-leather saddle. All leather saddles used on Paramounts are "broken-in" at the Schwinn factory.



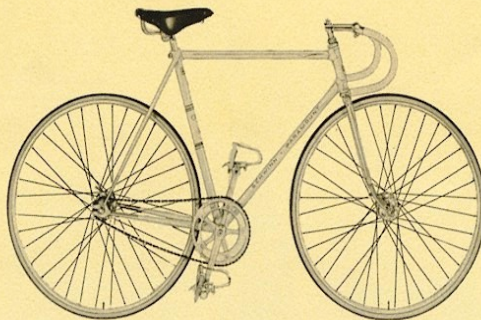

P-14

11. TOOLS: Included with the Paramount Track Bike is a tool kit containing Campagnolo tools for disassembling and adjusting the crank set and for adjusting the saddle and seat post.

12. COLORS: The Paramount Track Bike is available in your choice of all Schwinn colors or all chrome finish at extra cost.

13. WEIGHT: 18 lbs. (Weight will vary depending on frame size, options and accessories.)

AVAILABLE OPTIONS ON THE PARAMOUNT TRACK BIKE

1. FRAME OPTIONS:

Standard size frames of 20", 21", 22", 23", 24", 25" or 26" may be ordered at.....*no extra cost*
 Custom built, made to measure frame..... *\$40.00 extra cost*
 (For complete information on frame sizes, see page 6.)

2. WHEEL OPTIONS:

Weinmann Aluminum alloy wood filled rims on Campagnolo Track large flange hubs.....*standard equipment*
 Scheeren Weltmeister rims (8 oz.) on Campagnolo Track large flange..... *\$3.95 per pair extra cost*

3. HANDLEBAR OPTIONS:

Cinelli steel track bar and stem..... *standard equipment*
 Cinelli steel track bar and double adjustable steel stem..... *\$3.50 extra cost*
 Cinelli Aluminum alloy road handlebar and stem..... *\$3.95 extra cost*

4. CRANK AND SPROCKET OPTIONS:

165MM (6½") crank length.....*no extra cost*
 170MM (6¾") crank length.....*no extra cost*
 ½" Pitch Sprockets
 50T front sprocket..... *standard equipment*
 49T, 51T, 52T..... *\$2.50 extra cost*
 16T rear sprocket..... *standard equipment*
 14T, 15T..... *no extra cost*
 1" Pitch Sprockets
 25T front sprocket..... *standard equipment*
 23T, 24T, 26T..... *\$2.50 extra cost*
 8T rear sprocket..... *standard equipment*
 7T, 9T..... *no extra cost*

5. SADDLE OPTIONS:

Brooks Professional leather saddle..... *standard equipment*
 Unica Nitor nylon saddle..... *no extra cost*

6. ACCESSORY OPTIONS:

Schwinn Approved (Weinmann) side pull front caliper brake.... *\$5.00 extra cost*
 Fork drilled for caliper brake..... *\$1.25 extra cost*

7. COLOR OPTIONS:

Radiant colors—Campus Green, Sky Blue, Violet, Flamboyant Red, Sierra Brown, Coppertone, Burgundy
 Opaque colors—Kool Lemon, Kool Orange, Black, White, Silver Mist
 Chrome head lugs and fork crown..... *\$30.00 extra cost*
 All chrome finish..... *\$30.00 extra cost*

*Fair trade retail price in fair trade states. Suggested retail price in all other states. Prices and specifications subject to change without notice. Zone 2 and Zone 3 prices reflect higher shipping costs.

Schwinn Paramount®

STANDARD SIZE FRAMES

The Professional Road Racing Paramount, the Deluxe Paramount and the Paramount Track Bike are available in your choice of seven standard frame sizes (Frame size is measured by the length of the seat mast from the center of the crank hanger to the top of the seat mast). To determine the proper size frame for your leg measurement, consult the proper fit chart.

The sizes of the standard size frames are: 20", 21", 22", 23", 24", 25" and 26". On these standard size frames the head and seat mast are parallel and, on the Professional Road Racing Paramount and the Deluxe Paramount, the head and seat mast form an angle of 73° with the wheelbase center line' on the Paramount Track Bike the head and seat mast are set at an angle of 74°.

In most instances, one of these standard size frames will fit most riders comfortably. To order one of these standard size frames, simply indicate your choice on the Special Paramount Order Form.

CUSTOM BUILT MADE-TO-MEASURE FRAMES

In the event that you wish to order a frame smaller than 20" or larger than 26" or if you wish to alter the dimensions of the frame you may order a custom built, made-to-measure frame at an extra cost of \$40.00. If you wish to order a custom built frame, please fill in the critical dimensions on the appropriate drawing and return the drawing with the Special Paramount Order Form.

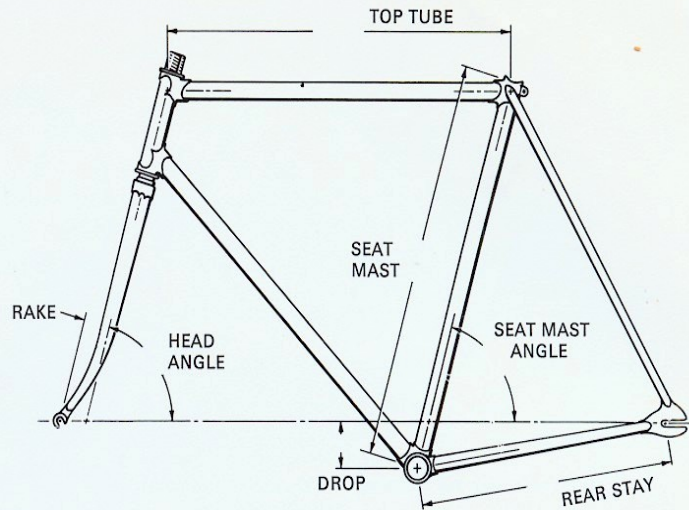

Paramount® Track Bike model P14



P-14

NOTE:

Orders for custom built frames are subject to approval by the Schwinn Engineering Department for sound design and construction feasibility.



P-13



P-15

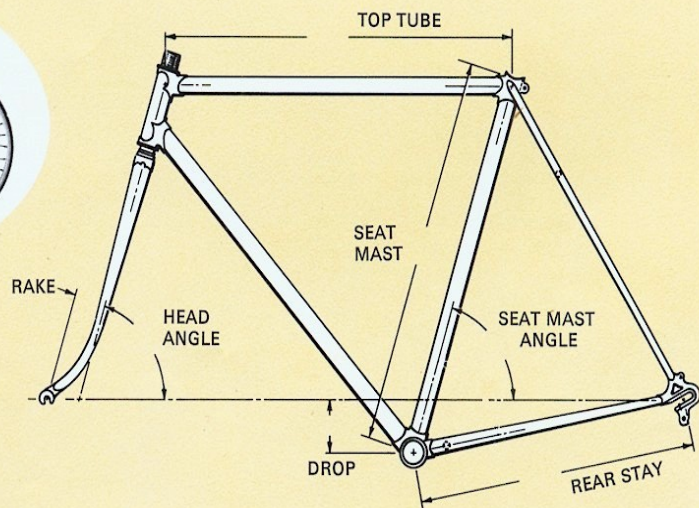

Professional Road Racing and
Deluxe Paramount® models P13-9/P15-9



Schwinn Sports Tourer™ ten-speed model 832/834/836

DESCRIPTION • SCHWINN SPORTS TOURER MODEL NOS. 832-9, 834-9, 836-9

WHEEL SIZE: 27"		PRICE*		
FRAME SIZE: 832-22",	ZONE 1	ZONE 2	ZONE 3	
834-24", 836-26"	\$196.00	\$198.00	\$199.00	

THE EQUIPMENT ON THE SCHWINN SPORTS TOURER

1. FRAME COMPONENTS: The frame of the Schwinn Sports Tourer is manufactured from 4130 chrome molybdenum steel alloy tubing. All chrome-molybdenum alloy steel combines strength and light overall weight. All joints are hand brazed and reinforced with pressed-in sleeves.

2. FRAME SPECIFICATIONS: The Schwinn Sports Tourer is available in a 22" frame, 24" frame or 26" frame. The 26" frame model has a larger diameter top tube for extra strength.

3. FORK: Tubular fork with chrome plated fork cap. Six inches of chrome trim.

4. WHEELS: Assembled with Weinmann aluminum alloy rims on Schwinn-Approved Deluxe large flange hubs. Spokes are .080-.060 gauge and are chrome plated. The hubs are equipped with a quick release mechanism which allows the wheels to be removed and installed without tools.

5. TIRES: Schwinn-Approved 27" x 1 1/4" Puff Gumwall tires.

6. HANDLEBAR: Randonneur handlebars. These handlebars have a shallower drop and more extended ends.

7. CRANK SET: Aluminum alloy crank set with 170MM (6 3/4") crank arms. The chainwheels are 36 and 54 teeth and the crank set is supplied with a lightweight style chainguard.

8. PEDALS: Union aluminum alloy rattrap pedals with Sprint toe clips and straps.

9. SADDLE: Brooks B-15 all-leather saddle.

10. DERAILLEURS AND FREEWHEELS: Campagnolo Gran Turismo rear derailleur and Schwinn-Approved front derailleur. Derailleurs are operated from Schwinn Twin-Stik controls mounted on the frame head. The rear freewheel sprocket is Schwinn-Approved with sealed bearings and built-in chainguard. The sprockets are 14, 17, 22, 28 and 34 teeth. The 28 and 34 teeth sprockets are special 1" pitch configuration which allows for easier shifting into low ranges.

11. GEAR RANGE: The gear range is 28 to 104 with the steps as follows:

36-34 28	36-28 35	54-34 43	36-22 44	54-28 52
36-17 57	54-22 66	36-14 69	54-17 86	54-14 104

This gear range is the broadest currently available on any production bicycle.

12. COLORS: Silver Mist, Lemon, Orange, Sierra Brown and Burgundy.

13. WEIGHT: 31 lbs. (Weight will vary according to frame size.)

* Fair trade retail price in fair trade states. Suggested price in all other states. Prices and specifications subject to change without notice. Zone 2 and Zone 3 prices reflect higher shipping costs.

SCHWINN



SCHWINN

*Schwinn Super Sport™ ten-speed men's model 822/824
ten-speed ladies' model 869/872*

**DESCRIPTION • SCHWINN SUPER SPORT
MODEL NOS. 822-9, 824-9, 869-9, 872-9**

WHEEL SIZE 27"	PRICE*		
FRAME SIZE 822-22",	ZONE 1	ZONE 2	ZONE 3
824-24", 869-19", 872-22"	\$136.95	\$138.95	\$139.95

THE EQUIPMENT ON THE SCHWINN SUPER SPORT

- 1. FRAME COMPONENTS:** 4130 chrome molybdenum alloy steel with hand brazed joints and reinforcing pressed in sleeves. Chrome molybdenum alloy steel combines the best in strength with a low overall weight.
- 2. FRAME SPECIFICATIONS:** The men's style Super Sport is available in 22" and 24" frame sizes (frame sizes are measured from the center of the crank hanger to the top of the seat mast). The ladies' style Super Sport is available in 19" and 22" frame sizes.
- 3. FORK:** Tubular fork with chrome plated fork cap.
- 4. WHEELS:** Assembled with Weinmann aluminum alloy rims on Schwinn-Approved large flange hubs. The hubs are equipped with a quick release mechanism which allows the wheels to be removed and installed without the use of tools. The spokes are .080-.060 gauge and have a bright zinc plating.
- 5. TIRES:** The Super Sport models are equipped with Schwinn-Approved 27" x 1 1/4" Puff Gumwall tires.
- 6. HANDLEBARS:** The men's style Super Sport is equipped with a Randonneur style handlebar. The ladies' style model is equipped with Schwinn manufacture modified tourist style handlebar.
- 7. CRANK SET:** The Super Sport models are equipped with Schwinn manufacture double plateau front sprockets with built-in chainguard. The sprocket sizes are 39 and 52 teeth.

8. PEDALS: Men's Style—Aluminum alloy rattrap pedals with Sprint toe clips and straps. Ladies' Style—Deluxe Schwinn-Approved Bow Sport pedals.

9. SADDLE: The men's Super Sport model is equipped with the Brooks B-16 all-leather saddle. The ladies' model Super Sport is equipped with a Schwinn-Approved mattress saddle with chrome plated dual springs and undercarriage.

10. BRAKES: Schwinn-Approved Weinmann center pull caliper brakes are standard equipment on both men's and ladies' Super Sports. The men's Super Sport is equipped with large hooded levers with quick release button. The ladies' style Super Sport is equipped with tourist style brake levers.

11. FENDERS: The ladies' Super Sport is equipped with chrome plated steel fenders.

12. DERAILLEURS AND FREEWHEELS: Schwinn-Approved rear derailleur with long cage and Schwinn-Approved front derailleur. The derailleurs are operated from Schwinn Twin-Stik controls mounted on the frame head. The rear freewheel sprockets are Schwinn-Approved with sealed bearings and built-in chainguard on small high gear sprocket. The sprocket sizes are 14, 17, 21, 26 and 32 teeth.

13. GEAR RANGE: The gear range is 33 to 100 with the steps as follows:

39-32 33	39-26 41	52-32 44	39-21 50	52-26 54
39-17 62	52-21 67	39-14 75	52-17 83	52-14 100

14. COLORS: Sierra Brown, Campus Green, Lemon and Burgundy.

15. WEIGHT: 33 lbs. (Weight will vary slightly depending on frame size.)

* Fair trade retail price in fair trade states. Suggested retail price in all other states. Prices and specifications subject to change without notice. Zone 2 and Zone 3 prices reflect higher shipping costs.

Proper Fit Chart

Paramount® standard frame sizes

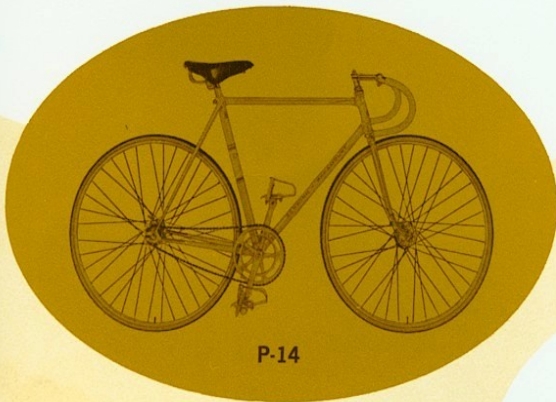
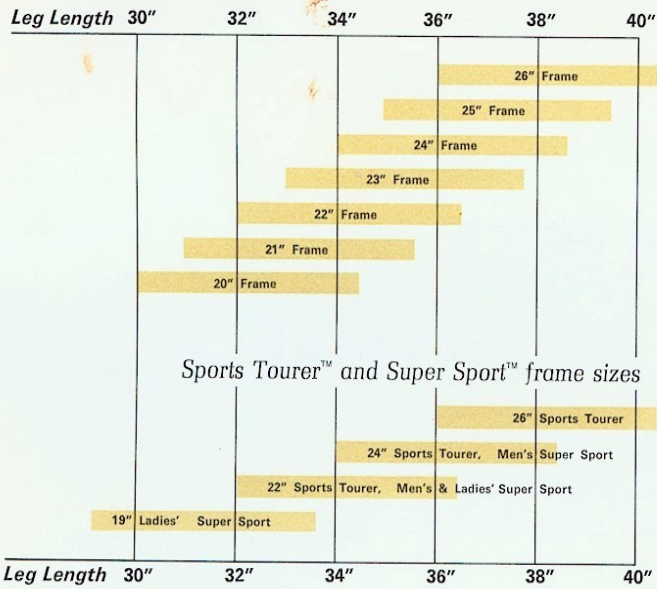

P-14



SUPER SPORT



P-15



P-13



SPORTS TOURER

SCHWINN NO-TIME-LIMIT

Guarantee

Schwinn bicycles are guaranteed against all defects in material and workmanship . . . no time limit.

Schwinn will replace . . . without charge . . . any original part that is determined by the factory to be defective under the terms of the guarantee.

Failure due to accident, abuse, neglect, normal wear, improper assembly or maintenance by anyone other than a Franchised Schwinn Dealer or use of other than genuine Schwinn parts is not covered.

Free Thirty-Day Checkup

Each Schwinn Bicycle will be fully assembled by the Franchised Schwinn Dealer at time of purchase and will be entitled to receive a free thirty-day checkup by the same Franchised Schwinn Dealer within the first thirty days of operation . . . such checkup to include free replacement of any parts found to be defective, free inspection and adjustment of all functional parts and assemblies . . . but not including any repair due to accident or abuse, neglect, normal wear, improper assembly or maintenance by anyone other than a Franchised Schwinn Dealer or use of other than genuine Schwinn parts.

Dealer labor charges are not covered by this guarantee after the free thirty day checkup except for any labor charges due to free replacement of a defective or broken frame within one year from date of original purchase at retail.

Replacement of defective parts and those dealer labor charges specified above shall be the sole remedy of any purchaser under the Schwinn Guarantee, and in no event shall Schwinn be liable on any implied warranty of merchantability or fitness, or for special consequential damage.

See your Schwinn Dealer for service under the Schwinn Guarantee or write for assistance to: Customer Service Department, SCHWINN BICYCLE COMPANY, 1856 North Kostner Avenue, Chicago, Illinois 60639.



SCHWINN[®] 1856 NORTH KOSTNER AVENUE • CHICAGO, ILLINOIS 60639